

品質 · 技術 · 專業 · 服務

QUALITY · TECHNIQUE · PROFESSIONAL · SERVICES



財佑機械實業股份有限公司
Chaiyo Machinery Industrial Co., Ltd.



財佑機械實業股份有限公司

地址：台灣省台中市大里區大衛路 50-1 號

TEL：04-24066161

FAX：04-24076161

E-mail：chaiyo.a68@msa.hinet.net

www.chaiyo.com.tw

Chaiyo Machinery Industrial Co., Ltd.

No. 50-1, DaWei Rd., Dali Dist.,

Taichung City 41259, Taiwan (R.O.C.)

TEL：886-4-24066161

FAX：886-4-24076161

E-mail：chaiyo.a68@msa.hinet.net

www.chaiyo.com.tw

全國首創無接點螺旋葉片

There is no contact spiral blade to initiate in the whole country

螺旋輸送機專業製造

The spiral machine conveyer is made professionally



品質 · 技術 · 專業 · 服務

QUALITY · TECHNIQUE · PROFESSIONAL · SERVICES



● 財佑機械實業股份有限公司 ●

公司簡介 COMPANY PROFILE

財佑公司成立於1984年，至今已逾三十餘年公司創辦人董事長「陳金池」先生為領域先趨專業製造螺旋輸送設備，投入心血不斷求新與技術成為全國首創申請【專利】，「連續式無接點螺旋葉片」製造商，陳董事長在業界受到許多好評與肯定並累積多年經歷再創先趨，獨自研發製造「無軸式螺旋葉片」生產機台，降低各客戶的製造成本，因應時代的進步，財佑公司一直秉持著四大原則「品質」、「技術」、「專業」、「服務」四大經營理念，不斷自我突破，繼續引進「高科技的設備」可製造更厚鋼板及超大型葉片產品以及專業性人才提升公司經營成效更能為您提供優質的服務和業界攜手合作，共同達成改善工作環境、節省時間人力資源、降低生產成本之未來目標。



目錄

主要產品



螺旋各種樣式(螺旋與其它零件系列 / 葉片系列 / 中吊零組件)	1-4
“U”型槽螺旋輸送機 U-type screw conveyor	5
“U”型槽多軸式輸送機	6
CNC車床的排屑機 The chip remover of CNC lathe	7
無心軸輸送機 No mandrel conveyor	8
單鏈條輸送機&雙鏈條輸送機 Single-chain conveyor & Double-chains conveyor	9
圓型螺旋輸送機 Cylindrical type screw conveyor	10
圓型輸送機 Cylindrical conveyor	11
體積式螺旋定量機 Volumetric type, spiral quantitative machine	12
磅秤定量機 Platform scales quantitative machine	13
儲存桶破壞架橋供料機&簡易型破碎機 Anti-bridging hopper & Easy type crusher	14
混合機&雙軸式液體攪拌機 Mixer& Biaxial-type liquid agitator	15
固液分離脫水機 Solid-liquid separation dehydrating machine	16
浮儲槽 Floating storage tank	17
分離洗滌機&儲槽輸送機 Separation and rinse machine & Storage tank conveyor	18
解標籤機&吹標籤機 Label Peeling Machine & Blowing label machine	19
滾桶式輸送機 Drum-type conveyor	20
液體真空及壓力儲料桶&篩選機及儲料桶 The liquid vacuum and pressure material hopper	21
現場照 Site photos	22-23



螺旋各種樣式

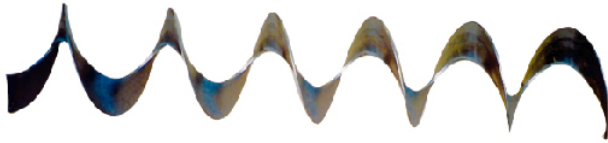

一體成形無接點葉片
One-piece-formed seamless vane

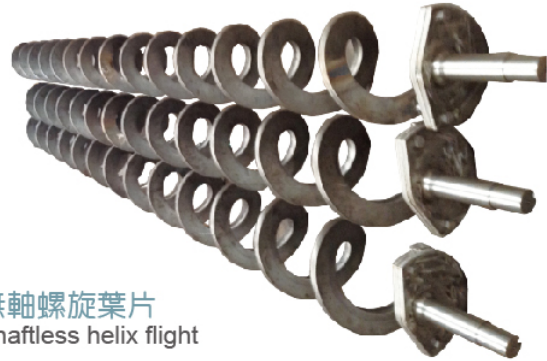

無軸螺旋葉片
Shaftless helix flight



片狀螺旋葉片
Screw Flight Sheet

片狀螺旋桿

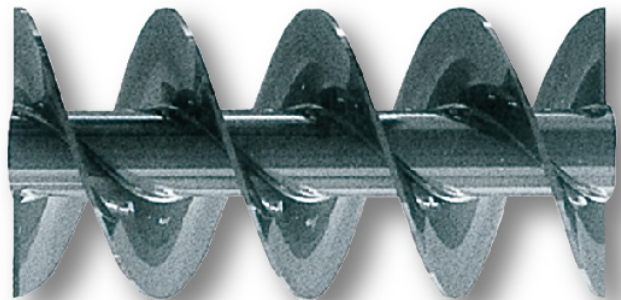
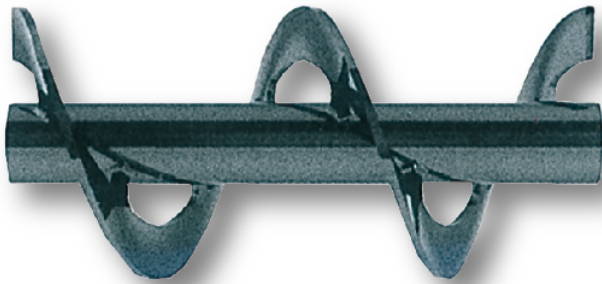

雙螺紋螺旋桿
Propeller

點空式螺旋桿

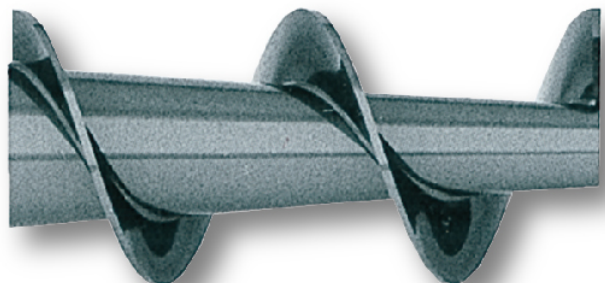
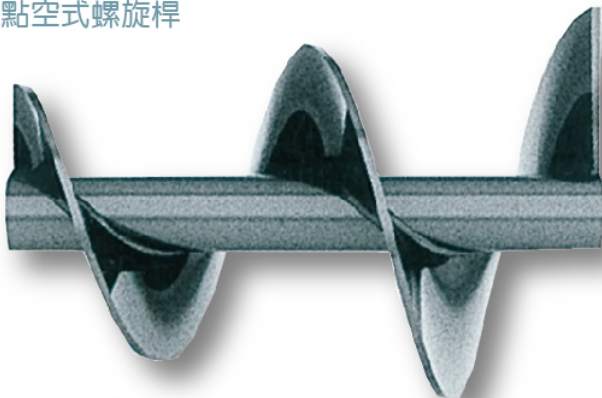

大小頭擠壓螺旋桿
Big head and small head extruding screw

大小頭擠壓螺旋桿
Big head and small head extruding screw

螺旋與其它零件系列

Spiral and other part series



螺旋桿
Propeller



磨耗可更換式螺旋桿
Wearing and replaceable type screw

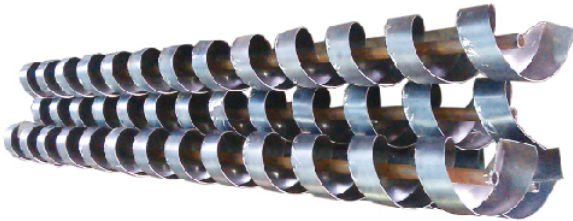

滑道式螺旋桿
Slide-type screw



特殊耐磨材質雙螺紋
(適用磨耗較高物體如:煤礦)
special and wearproof quality, double threads
(Whether suitable to wear and tear high object,
for instance. Colliery)

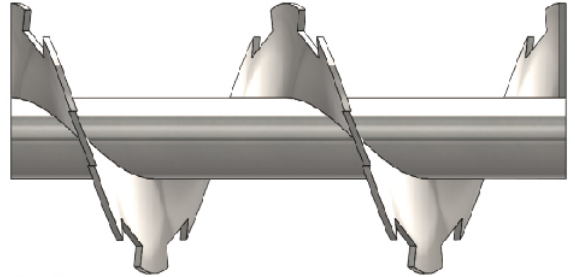

鋸齒狀螺桿
Zigzag screw



磨耗可更換式螺旋桿
Wearing and replaceable type screw

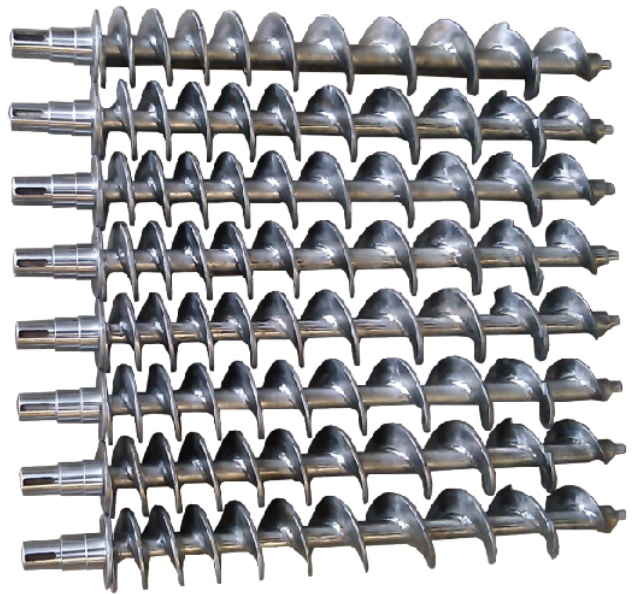

多軸式穩定出料螺旋桿
Multi-axis type stabilizing discharge screw

產品可客製化

葉片可製造外徑20mm以上
最大可達2500mm

厚度: 2.0-50mm

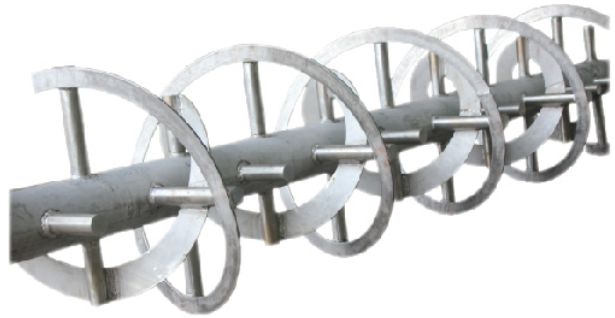

攪拌式螺旋桿
Mix-type screw



懸空式螺旋桿
Overhead-type screw

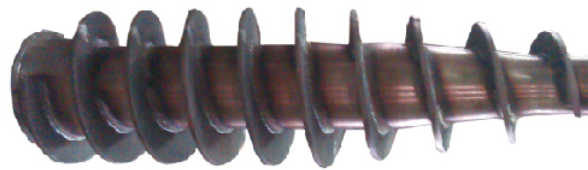

大小頭擠壓螺旋桿
Big head and small head extruding screw

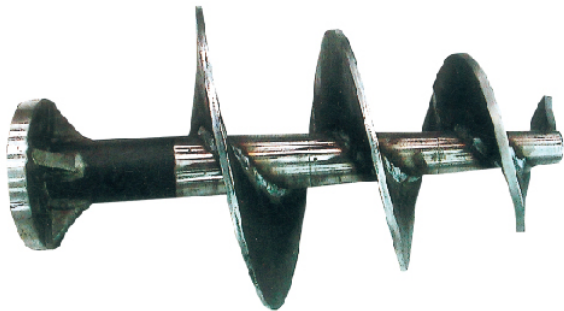

大小頭擠壓螺旋桿
Big head and small head extruding screw



大小頭擠壓螺旋桿
Big head and small head extruding screw



三螺紋攪拌螺旋桿
Three-threaded agitating screw



彈簧軟式螺旋葉片
Soft spring type helix flight

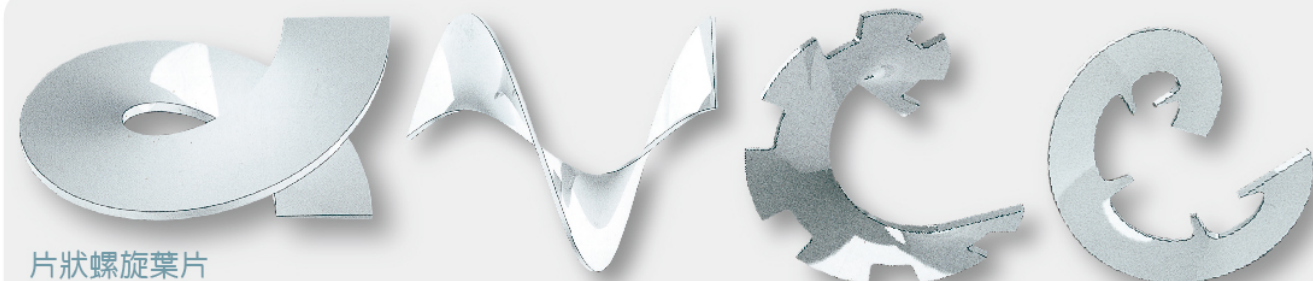

片狀螺旋葉片
Screw Flight Sheet

葉片系列

Vanes

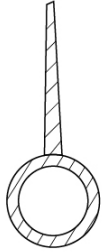

連續式無接點葉片
機械成型葉片剖面圖

Sectional drawing of
machine formed vanes

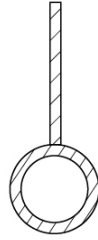

片狀葉片
傳統式葉片剖面圖

Sectional drawing of
conventional vanes



扇形狀葉片
扇形葉片剖面圖

Sector vanes
Sectional drawing of
sector vanes

中吊零組件



材質 碳化鎳



材質 銅、鐵鎳龍、石墨

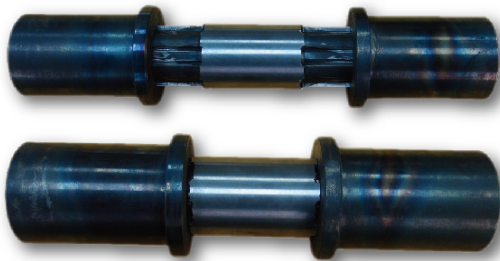

中吊軸心 快拆耐用

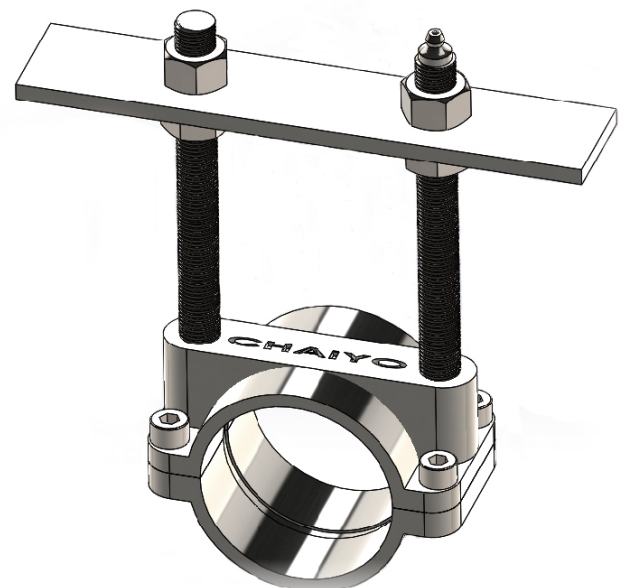

中吊零件保護套



軸承中吊

“U”型槽螺旋輸送機

U-type screw conveyor : 0.1 ~ 150 Ton/hr

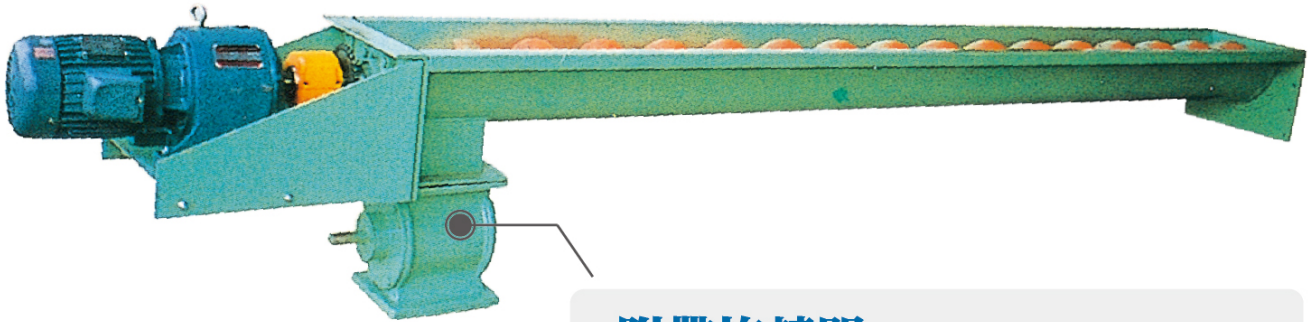

附帶旋轉閥

適用於集塵設備

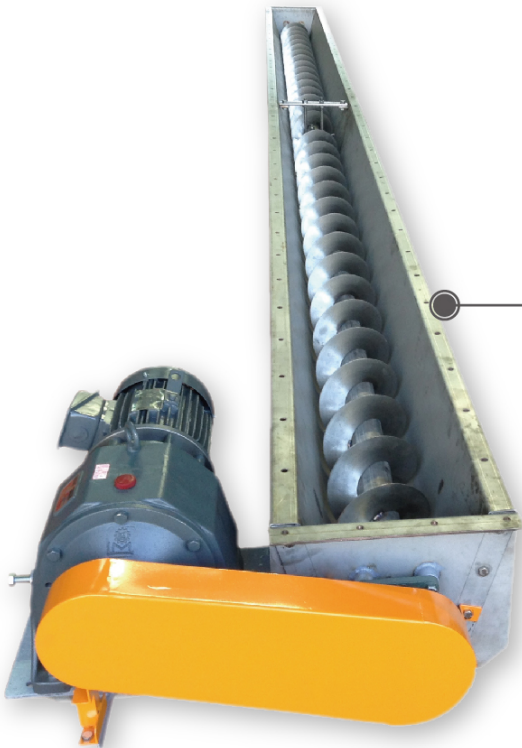

長距離輸送螺桿加裝中吊支撐

Long distance conveying screw with additional hanging support

雙軸式輸送機

功能：

適用混合攪拌輸送

可低溫加熱乾燥

Biaxial-type conveyor

FUNCTION:

Suitable for mixing and agitating conveying

Low temperature heating and drying



“U”型槽多軸式輸送機

Multi-axis type transporting

FEATURES :

Used in easy crosslinking material
can be installed hopper



多軸式運送式

功能：
適用容易架橋物料
可加裝儲料槽

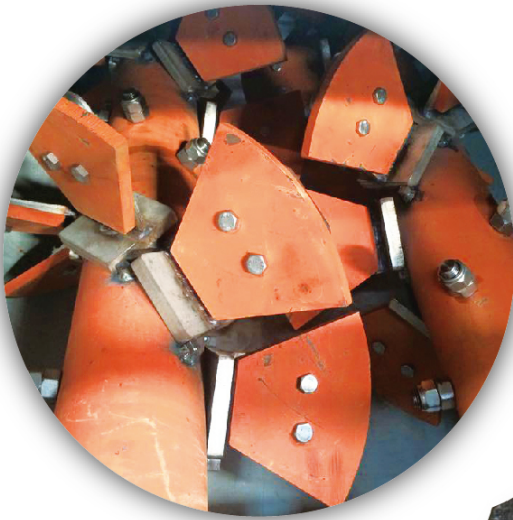

加溼機

功能：
可使粉塵加溼後方便運送運輸

Humidifier

FEATURES :

Convenient to conveying and transporting the dust after humidification

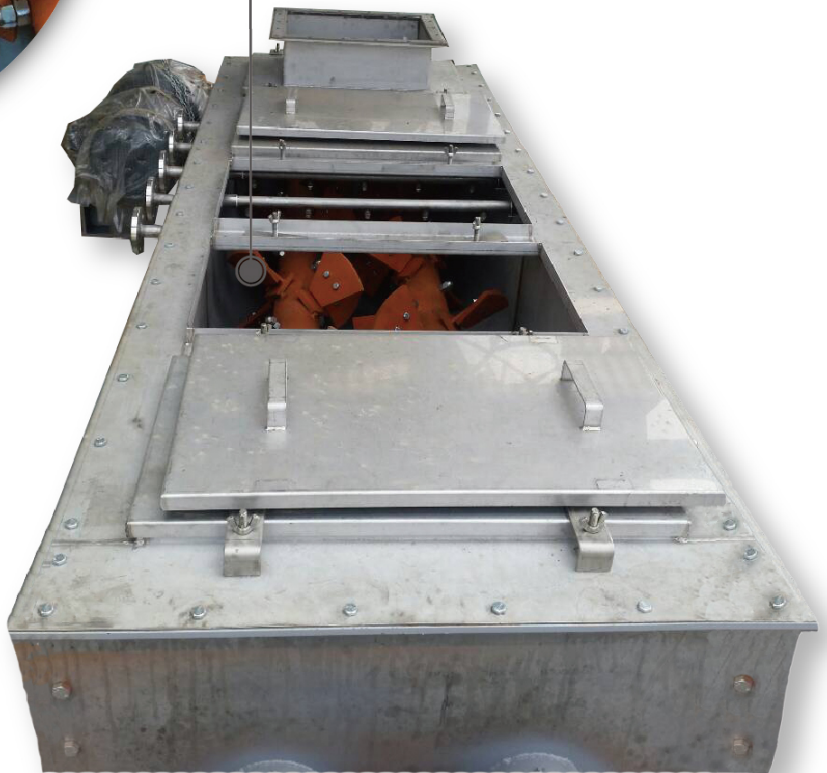

CNC車床的排屑機

The chip remover of CNC lathe

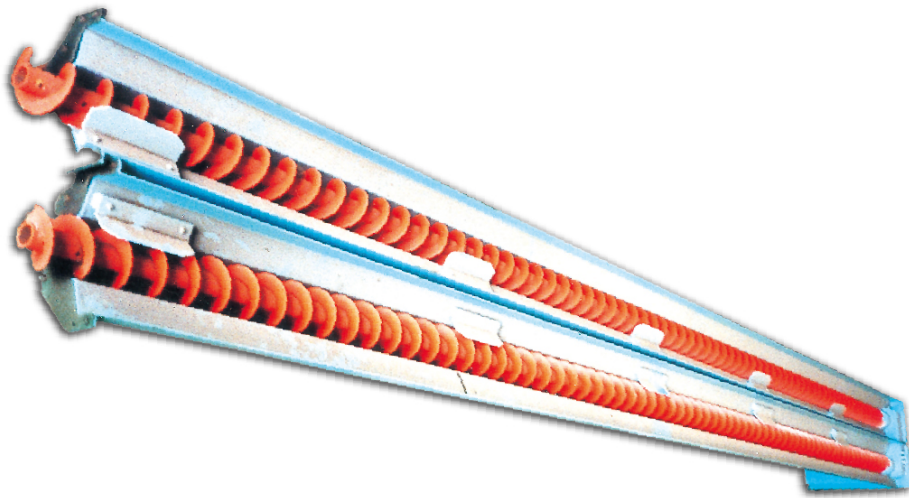

CNC車床的排屑機

功能：

一般最常用於CNC車床的排屑機
分有軸及無軸兩種型式。

The chip remover of CNC lathe

FEATURES :

Often used for the chip remover of CNC lathe.

Two types: shaft and without shaft

無心軸輸送機

No mandrel conveyor

無心軸輸送機

功能：

適用於粘稠物輸送

(一般較使用於污泥輸送)

No mandrel conveyor

FUNCTION :

Suitable for conveying thick and sticky material

(often used to convey sludge)

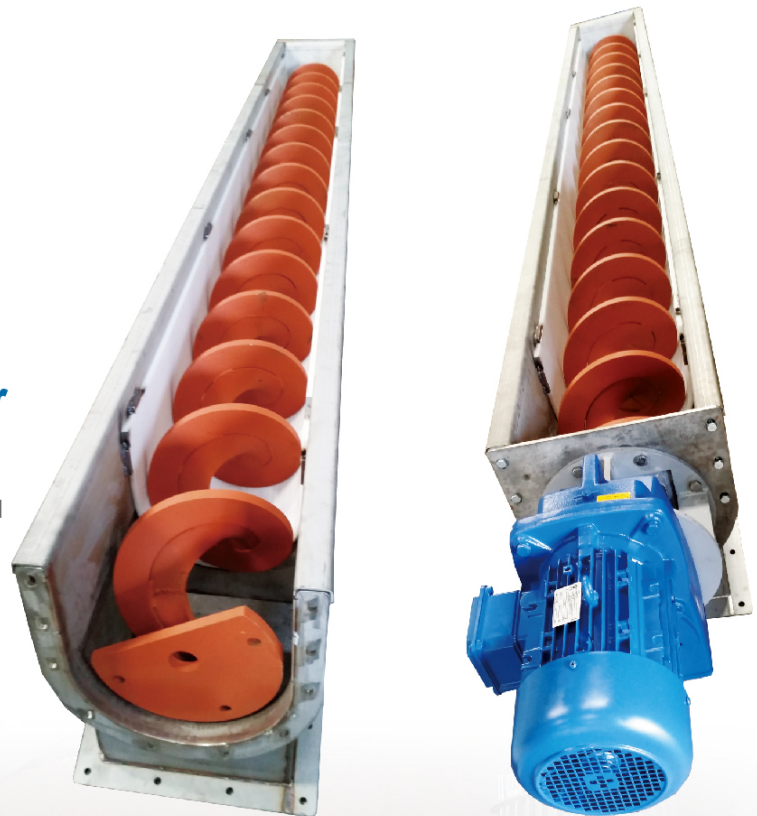

單鏈條輸送機&雙鏈條輸送機

Single-chain conveyor & Double-chains conveyor



雙鏈條輸送機

DOUBLE-CHAINS CONVEYOR

功能：

適用於中長距離輸送
輸送物以五穀類居多

FUNCTION:

Suitable for long distance conveying
Conveying material is mostly grains

單鏈條輸送機

SINGLE-CHAIN CONVEYOR



圓型螺旋輸送機

Cylindrical type screw conveyor

圓型螺旋輸送機

功能：

- 機械壽命長、永不變形。
- 按裝容易，不佔空間、時間。
- 傳送效率高，節約能源。

Cylindrical type screw conveyor

FEATURES :

- All vanes are one-piece-formed and seamless.
- The machine has a long service life, and will never be deformed.
- Easy installation and time saving. Less space occupied.
- High conveying efficiency and power saving.

圓型輸送機

Cylindrical conveyor

圓型輸送機

屬一般密閉式圓型輸送機。

功能：

易輸送有角度及粉體的物料。

Cylindrical conveyor

Airtight cylindrical conveyor

FEATURES :

Easy for delivering the objects with edges.



功能：

可任意移動需求位置輸送



功能：

出口端可上下調整送至需求位置

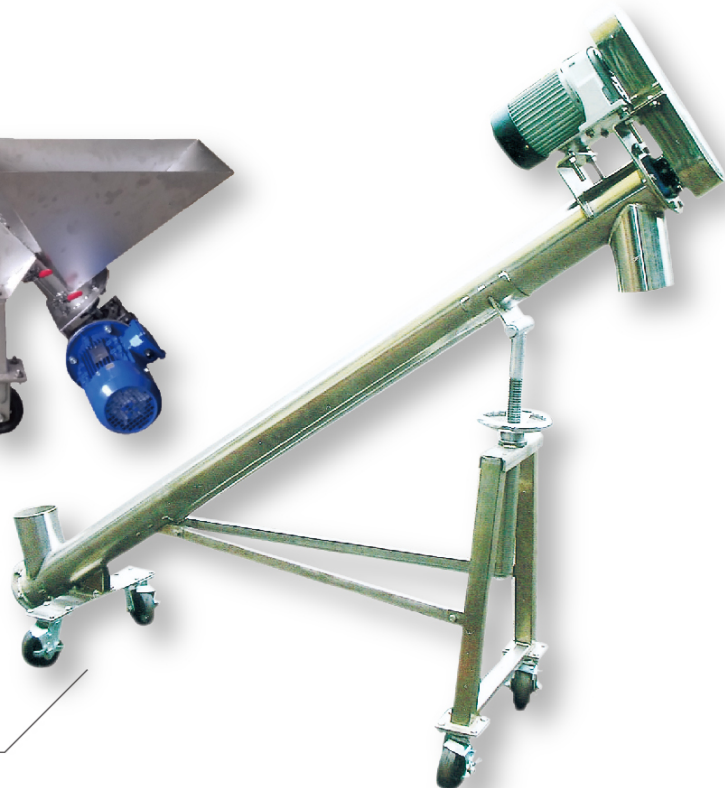

體積式螺旋定量機

Volumetric type, spiral quantitative machine

體積式螺旋定量機

功能：

- 可配合押出機定量供料。
- 可配合自動裝填機供料。
- 可配合自動磅秤之二段速度下料。
- 可配合廠商要求設計訂製。

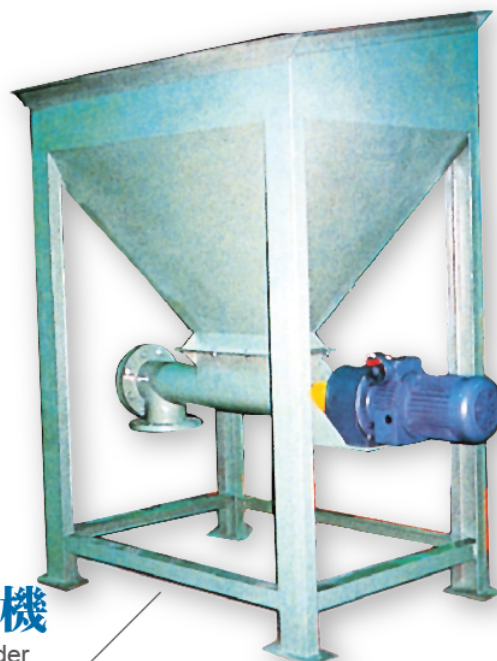

定量供料機

Quantitative feeder

Volumetric type, spiral quantitative machine

FEATURES :

- An extruder can be added for a quantitative feeding.
- An auto filling machine can be added for feeding.
- An auto weighing machine with 2 step speeds can be added to unload material.
- Customer-designed orders acceptable .



附有破壞架橋及擠壓功能之定量供料機

Quantitative feeder with standing rack and extruding function



磅秤定量機

Platform scales quantitative machine

磅秤定量機

功能：

產業界粉粒體成品包裝

磅秤定量機

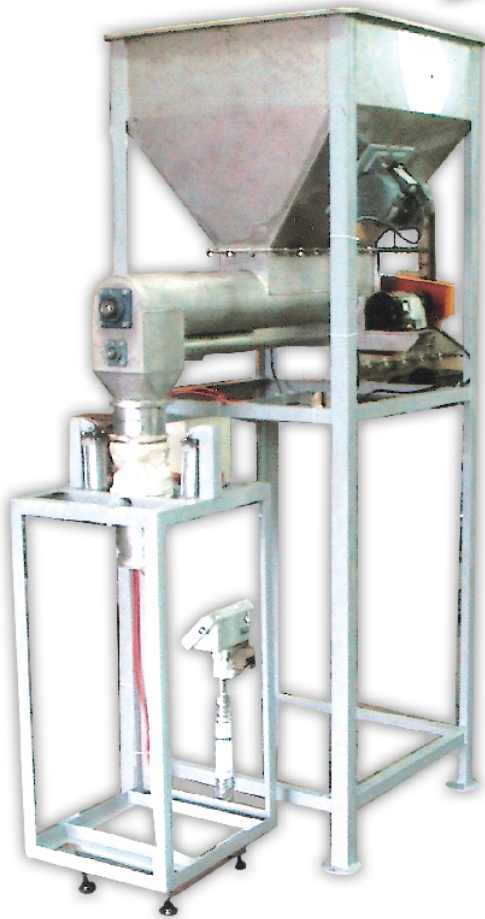

Platform scales quantitative machine

FEATURES :

“powder and grain” packing and quantitative machine in industrial cycles.

Platform scales quantitative machine

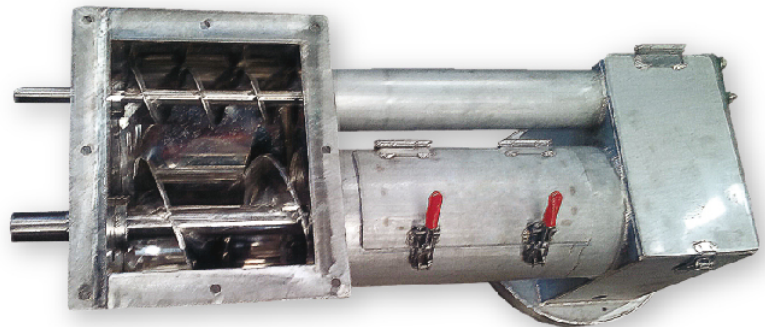

磅秤定量機

Platform scales quantitative machine

適用磅秤定量機

Suitable for scaling machine

儲存桶破壞架橋供料機&簡易型破碎機

Anti-bridging hopper & Easy type crusher

Chaoyo Machinery Industrial Co., Ltd.



儲存桶破壞架橋供料機

Anti-bridging hopper

簡易型破碎機

功能：
易將解開結晶體

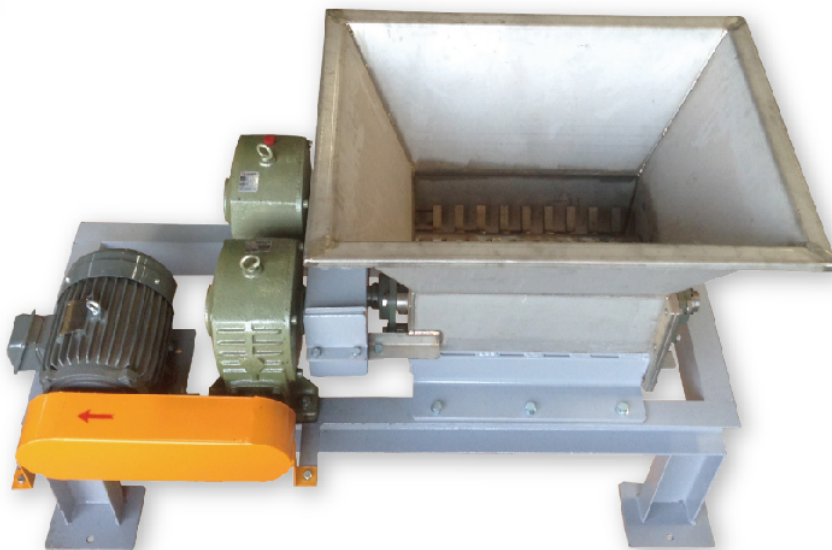

Easy type crusher

FEATURES :

Easy to break up the crystallization

混合機&雙軸式液體攪拌機

Mixer&Biaxial-type liquid agitator

Suitable for mixing several kinds of material together.

Option: Install a cooling type agitator, or a worm type agitating sleeve

Specifications subject to customer's requirement.

適用多種原料之混合

可加裝冷式攪拌或加熱乾燥攪拌功能

臥式混合機

功能：

混合原料及可兼乾燥功能

Horizontal type mixer

FEATURES :

Both mixing and drying



立式混合機

功能：

可將原料混合及暫存功能

Vertical type mixer

FEATURES :

Mix material, and then temporarily store it.



雙軸式液體攪拌機

Biaxial-type liquid agitator

固液分離脫水機

Solid-liquid separation dehydrating machine

Chaiyo Machinery Industrial Co., Ltd.

16



Separating solid from liquid PE and PET

FUNCTION :

Hydroextractor, for short (used for separating solid from liquid PE and PET) a solid and liquid separating machine, of chemical engineering equipment

固液分離機

功能：

一般簡稱脫水機
(本產品適用PE、PET的固液分離)
屬於化工機械的固液分離機。



浮儲槽

Floating storage tank

浮儲槽

功能：

將物體放入槽內，使物體比重分離，
利用水或其他溶液將物體浮於上下兩
層之後再行分離

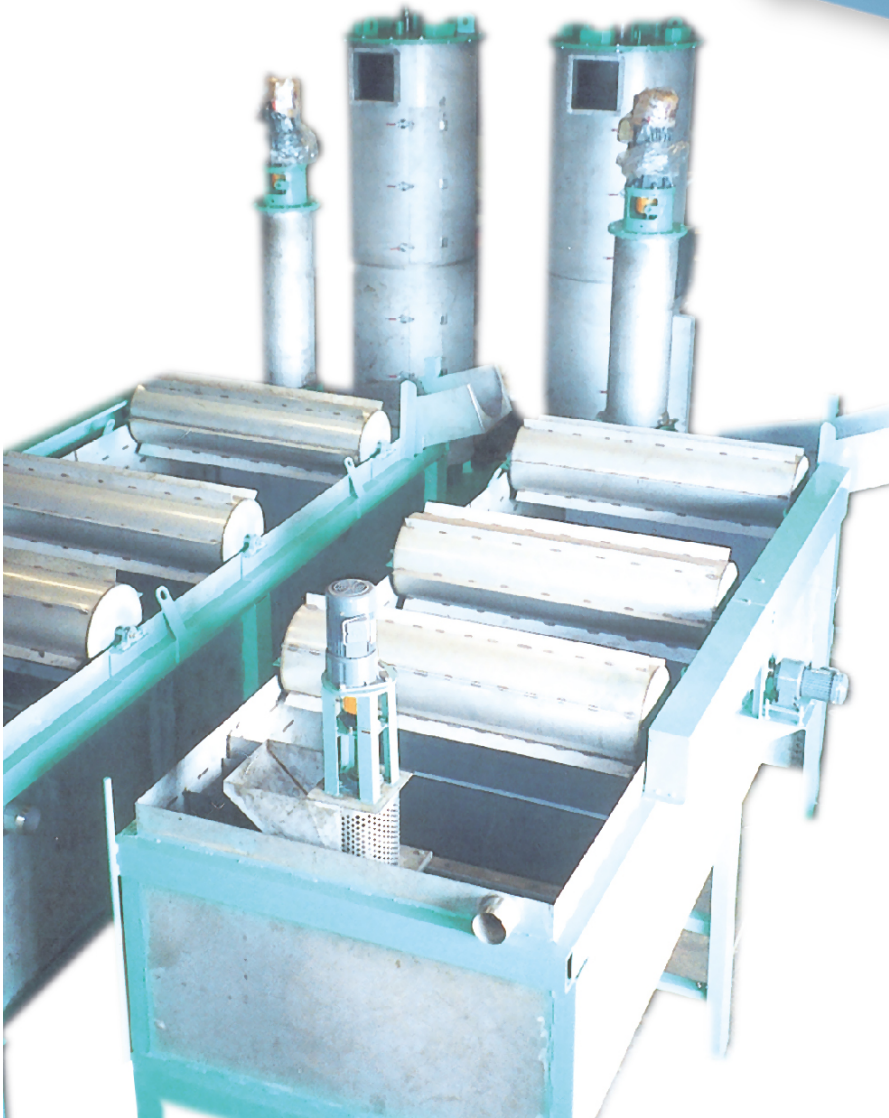

Floating storage tank

FUNCTION :

To put the object into the tank, so that the density will be separated. The separation will be incurred after the use of water or other solutions to float the object into upper and lower layers

分離洗滌機&儲槽輸送機

Separation and rinse machine & Storage tank conveyor

分離洗滌機

功能：

將原物料（瓶磚）放入後，
給予分離及洗滌等效果，
適用於保特瓶分離、洗滌
、脫標等功能。



Separation and rinse machine

FUNCTION :

Put the compressed bottles in form of a brick in the machine for separation and rinse. It is suitable for separating and rinsing PET bottles and peeling the labels.



儲槽輸送機

功能：

可存放大量原物料，
使後段製程可達連續
性的效果

Storage tank conveyor

FUNCTION :

Store a large amount of material so that the machine
can continuously work at the rear proceeding stage.

解標籤機&吹標籤機

Label Peeling Machine & Blowing label machine

解標籤機

功能：

適用瓶子與標籤解開

Label peeling machine

FUNCTION :

Used to peel the label from the bottle.

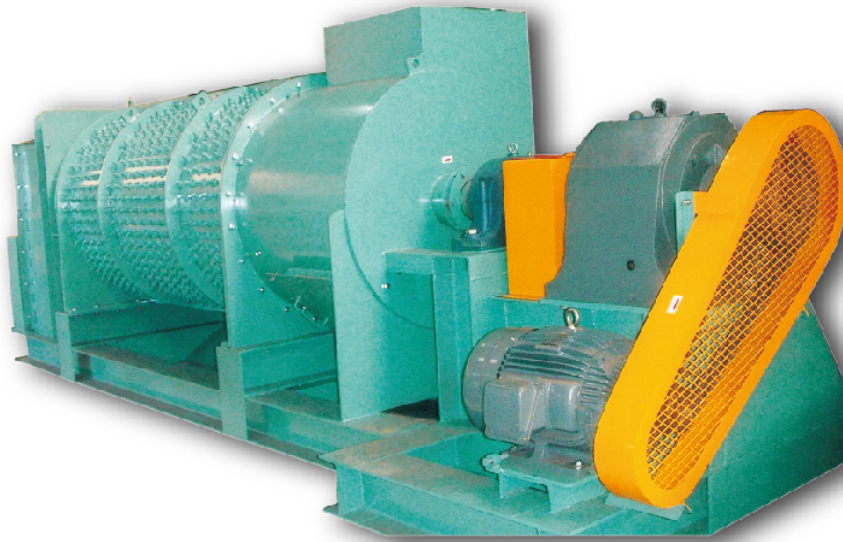

吹標籤機

功能：

使瓶子與標籤分離

Blowing label machine

FUNCTION :

To separate label from bottle

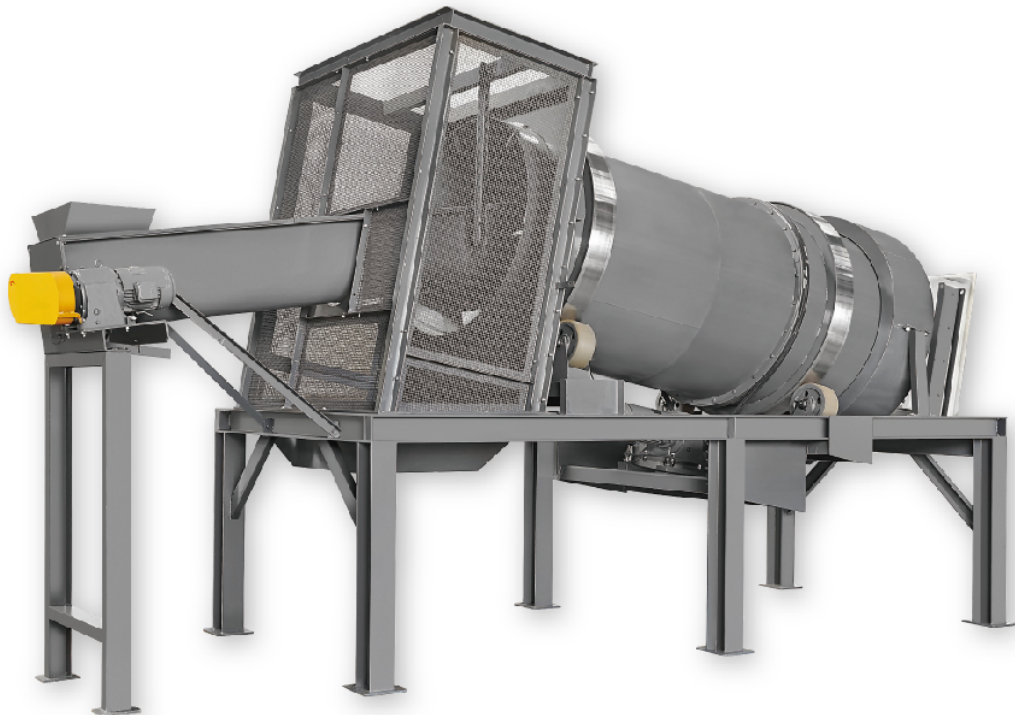

滾桶式輸送機&雙軸式液體攪拌機

Drum-type conveyor & Biaxial-type liquid agitator

滾桶式輸送機

功能：

可連續式撥料
適用於乾燥輸送

Drum-type conveyor

FUNCTION：

Continuous-type feeding
Suitable for dry conveying

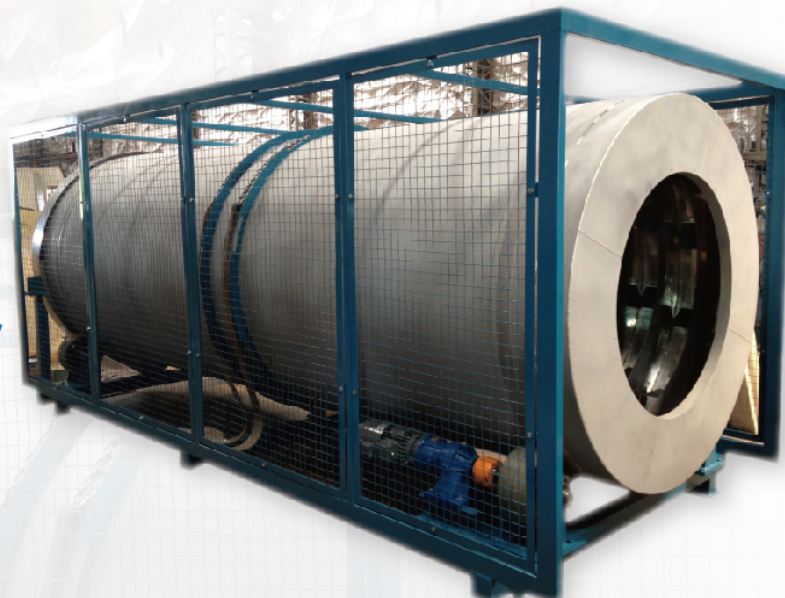

液體真空及壓力儲料桶&篩選機及儲料桶

The liquid vacuum and pressure material hopper

液體真空及壓力儲料桶

The liquid vacuum and pressure material hopper



篩選機及儲料桶



輸送汙泥設備



連續乾燥機設備



批次式高溫鍛燒爐設備

汗水處理輸送設備

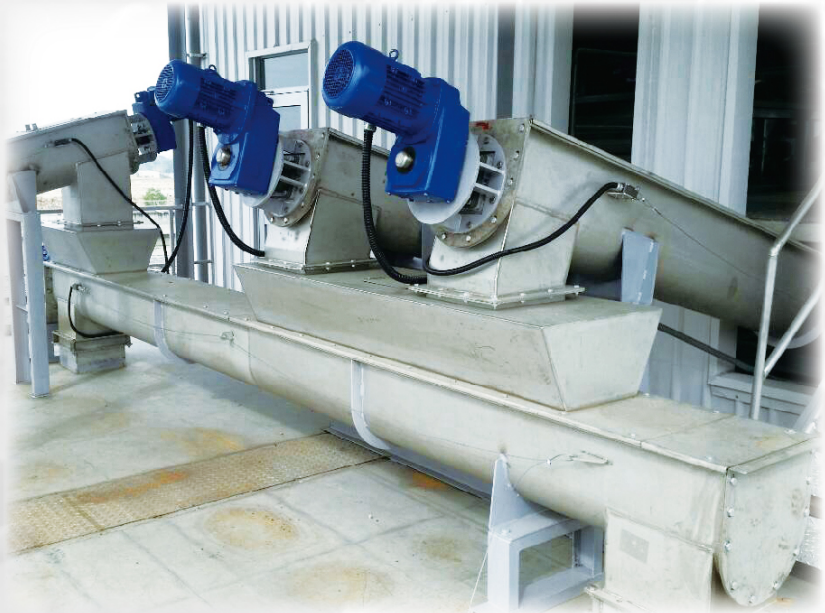

資源回收場整廠設備



菇場整場設備

